

EXPLODED VIEW & PARTS LISTING

Air Operated Double Diaphragm Pump

Model: DP-80-HD (XDP)
Stainless Steel Series



To Purchase:

- 800-990-7867
- sales@yamadapump.com
- Find My Rep

More Information:

- YouTube: @yamadapump
- yamadapump.com
- Data Sheets | CAD Drawings | Manuals Literature | BOM | Performance Curves

Trial Program

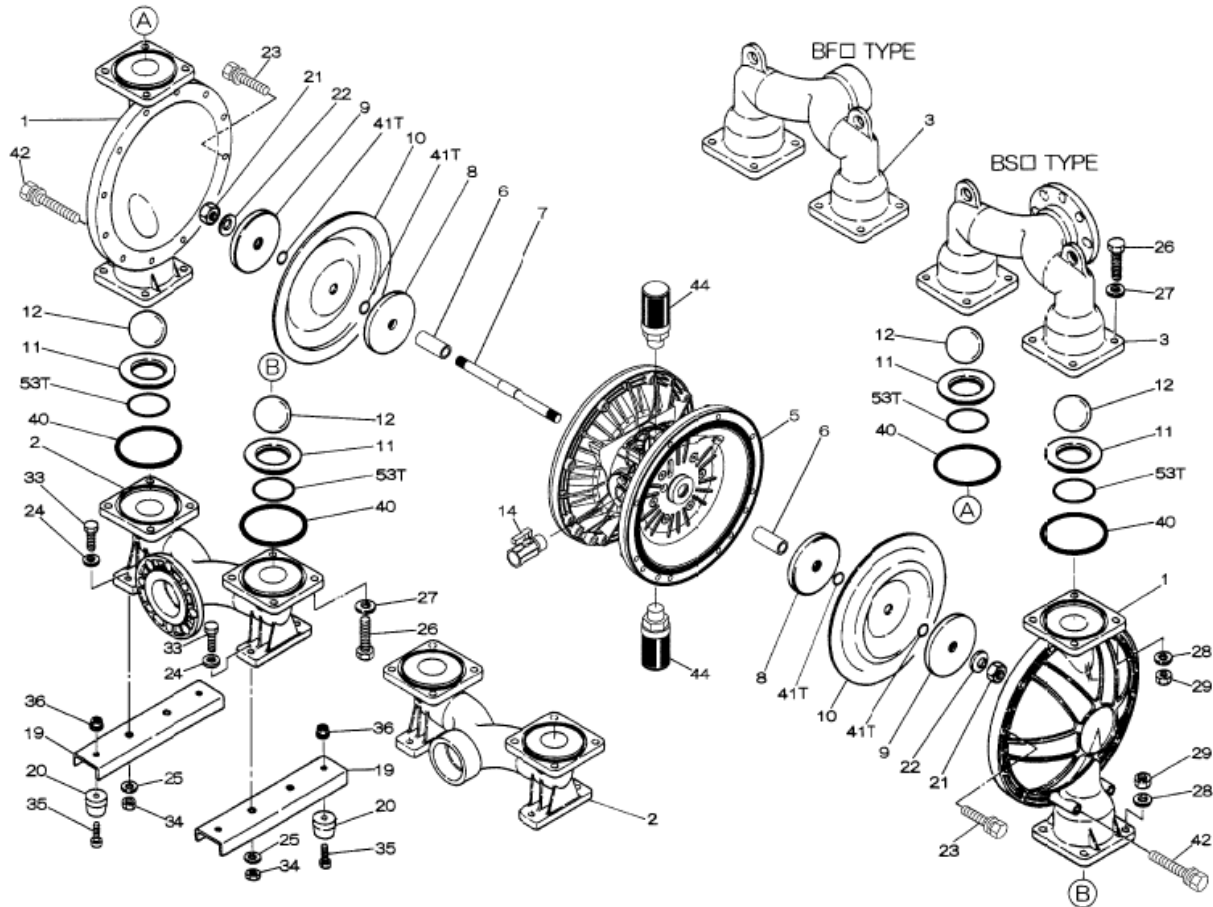

Air Operated Double Diaphragm Pump

804780 Center Body Assembly

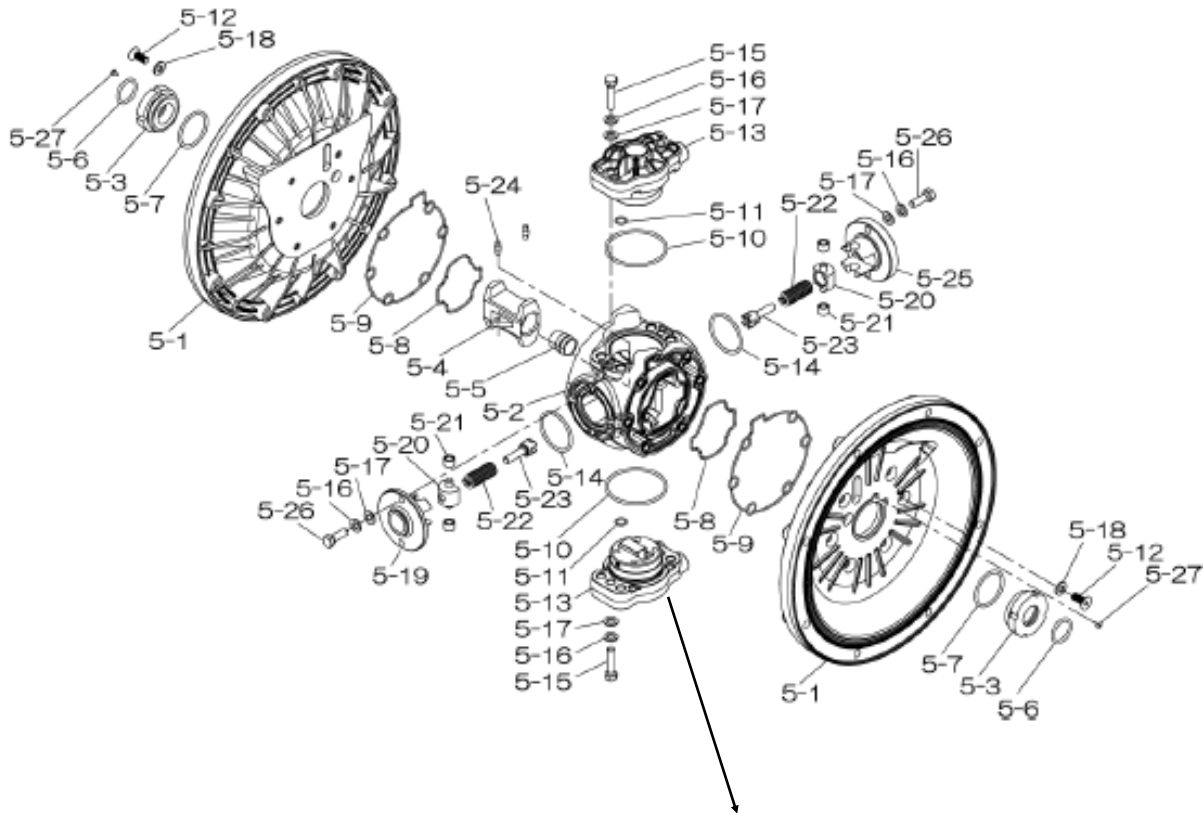

804784 Valve Body Assembly

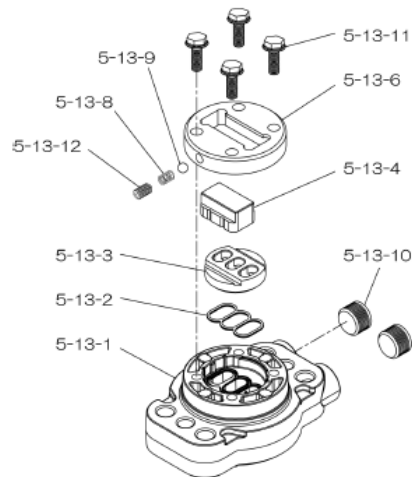

Air Operated Double Diaphragm Pump

	DP-80BSC-HD	DP-80BSN-HD	DP-80BSE-HD	DP-80BSH-HD	DP-80BSS-HD	DP-80BSV-HD			
	854508	854509	854510	854513	854514	854511			
REF. No.	PART No.	PART No.	PART No.	PART No.	PART No.	PART No.	DESCRIPTION	QTY.	REORDER
1	712933	712933	712933	712933	712933	712933	OUT CHAMBER	2	
2	712603	712603	712603	712603	712603	712603	IN MANIFOLD FLANGED	1	
2	712605	712605	712605	712605	712605	712605	IN MANIFOLD NPT	1	
3	712602	712602	712602	712602	712602	712602	OUT MANIFOLD FLANGED	1	
3	712604	712604	712604	712604	712604	712604	OUT MANIFOLD NPT	1	
5	804780	804780	804780	804780	804780	804780	CENTER BODY ASSY DP-80-HD	1	
5-1	716248	716248	716248	716248	716248	716248	AIR CHAMBER	2	
5-2	716256	716256	716256	716256	716256	716256	BODY	1	
5-3	773066	773066	773066	773066	773066	773066	THROAT BEARING	2	
5-4	716214	716214	716214	716214	716214	716214	SHUTTLE (CS)	1	
5-5	773047	773047	773047	773047	773047	773047	CENTER ROD GUIDE	1	
5-6	640023	640023	640023	640023	640023	640023	O RING	2	
5-7	640133	640133	640133	640133	640133	640133	O RING	2	
5-8	773040	773040	773040	773040	773040	773040	GASKET	2	
5-9	773041	773041	773041	773041	773041	773041	GASKET	2	
5-10	640138	640138	640138	640138	640138	640138	O RING	2	
5-11	640007	640007	640007	640007	640007	640007	O RING	8	
5-12	683812	683812	683812	683812	683812	683812	FLAT SOCKET	12	
5-13	804784	804784	804784	804784	804784	804784	VALVE BODY ASSY	2	
5-13-1	716244	716244	716244	716244	716244	716244	VALVE BODY	1	
5-13-2	773042	773042	773042	773042	773042	773042	GASKET	2	
5-13-3	716246	716246	716246	716246	716246	716246	SEAT (CS)	1	
5-13-4	773425	773425	773425	773425	773425	773425	BLOCK	1	
5-13-6	773426	773426	773426	773426	773426	773426	GUIDE PLATE	1	
5-13-8	706612	706612	706612	706612	706612	706612	SPRING INK	1	
5-13-9	686271	686271	686271	686271	686271	686271	BALL	1	
5-13-10	772934	772934	772934	772934	772934	772934	PLUG	2	
5-13-11	602300	602300	602300	602300	602300	602300	TAPPING BOLT	4	
5-13-12	610025	610025	610025	610025	610025	610025	HEX SOCKET HEAD SCREW	1	
5-14	640134	640134	640134	640134	640134	640134	O RING	2	
5-15	611153	611153	611153	611153	611153	611153	BOLT	4	
5-16	631420	631420	631420	631420	631420	631420	SPRING WASHER	8	
5-17	631013	631013	631013	631013	631013	631013	FLAT WASHER	8	
5-18	684987	684987	684987	684987	684987	684987	WASHER	12	
5-19	716249	716249	716249	716249	716249	716249	RETAINER	1	
5-20	713620	713620	713620	713620	713620	713620	SPRING GUIDE	2	
5-21	773067	773067	773067	773067	773067	773067	BUSH	4	
5-22	684537	684537	684537	684537	684537	684537	SPRING	2	
5-23	714446	714446	714446	714446	714446	714446	TRIP ARM	2	
5-24	700231	700231	700231	700231	700231	700231	PIN	2	
5-25	716216	716216	716216	716216	716216	716216	RETAINER	1	
5-26	611149	611149	611149	611149	611149	611149	BOLT	4	
5-27	686337	686337	686337	686337	686337	686337	TAPPING SCREW	2	
6	716253	716253	716253	716253	716253	716253	CENTER BUSH	2	
7	716252	716252	716252	716252	716252	716252	CENTER ROD	1	
8	711906	711906	711906	711906	711906	711906	CENTER DISK 80-R	2	
9	711907	711907	711907	711907	711907	711907	CENTER DISK 80SS-R	2	
10	771857	771704	771858	771705	771977	771801	DIAPHRAGM 80	2	
11	771958	771996	771999	771795	772005	771998	VALVE SEAT 80	4	
12	770559	770587	770596	773144	773174	770605	BALL 80	4	
14	686974	686974	686974	686974	686974	686974	BALL VALVE	1	
19	711912	711912	711912	711912	711912	711912	BASE	2	
20	771402	771402	771402	771402	771402	771402	FOOT RUBBER	4	

Air Operated Double Diaphragm Pump

	DP-80BSC-HD	DP-80BSN-HD	DP-80BSE-HD	DP-80BSH-HD	DP-80BSS-HD	DP-80BSV-HD			
	854508	854509	854510	854513	854514	854511			
REF. No.	PART No.	PART No.	PART No.	PART No.	PART No.	PART No.	DESCRIPTION	QTY.	REORDER
21	683408	683408	683408	683408	683408	706144	NUT	2	
22	682740	682740	682740	682740	682740	682740	WASHER	2	
23	621182	621182	621182	621182	621182	621182	BOLT	20	
24	631174	631174	631174	631174	631174	631174	FLAT WASHER	4	
25	631937	631937	631937	631937	631937	631937	WAVE WASHER	28	
26	621203	621203	621203	621203	621203	621203	BOLT	16	
27	631175	631175	631175	631175	631175	631175	FLAT WASHER	16	
28	631938	631938	631938	631938	631938	631938	WAVE WASHER	16	
29	628014	628014	628014	628014	628014	628014	NUT	16	
33	621177	621177	621177	621177	621177	621177	BOLT	4	
34	628013	628013	628013	628013	628013	628013	NUT	4	
35	611149	611149	611149	611149	611149	611149	BOLT	4	
36	682276	682276	682276	682276	682276	682276	NUT W/FLANGE	4	
40	640078	640078	684124	640078	684124	642078	O RING	4	
42	683543	683543	683543	683543	683543	683543	BOLT	4	
44	804697	804697	804697	804697	804697	804697	MUFFLER	2	
KIT	K80-MC	K80-MN	K80-ME	K80-MH	K80-MS	K80-MV	LIQUID END KIT		
KIT	K80-AM-DP-HD						AIR MOTOR KIT		

General Tools:

- Socket wrench - 24mm
- Hexagonal box wrench - 5mm, 6mm
- Small crowbars - 2 (B_C, B_N, B_E, B_V)
- Open-end wrenches - 19mm, 24mm
- Phillips head screw driver

Special Tools:

- Socket (804129) for a guide to remove the throat bearing (sold separately)

Miscellaneous:

- Assembly Oil - Turbine oil class 1 (equivalent to ISO VG32 grade)
- Nuts - M16 x 1.5
- Thread locker
- Urea grease grade (NLGI) No. 2, Shell Alvania Grease S1

Torque Requirements:

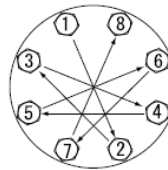

Tightening torque for center rod and out chambers.

Center Rod 43 ft-lbf {60 N-m}
Out Chambers 29 ft-lbf {40 N-m}

Tightening torque for manifold retainer bolts.

BSC/E/N/H/S/V-HD 18 ft-lbf {25 N-m}

Customer Notes

Model #: _____
 Description: _____
 Serial #: _____
 Date Installed: _____
 Department Location: _____
 Tag/Project: _____